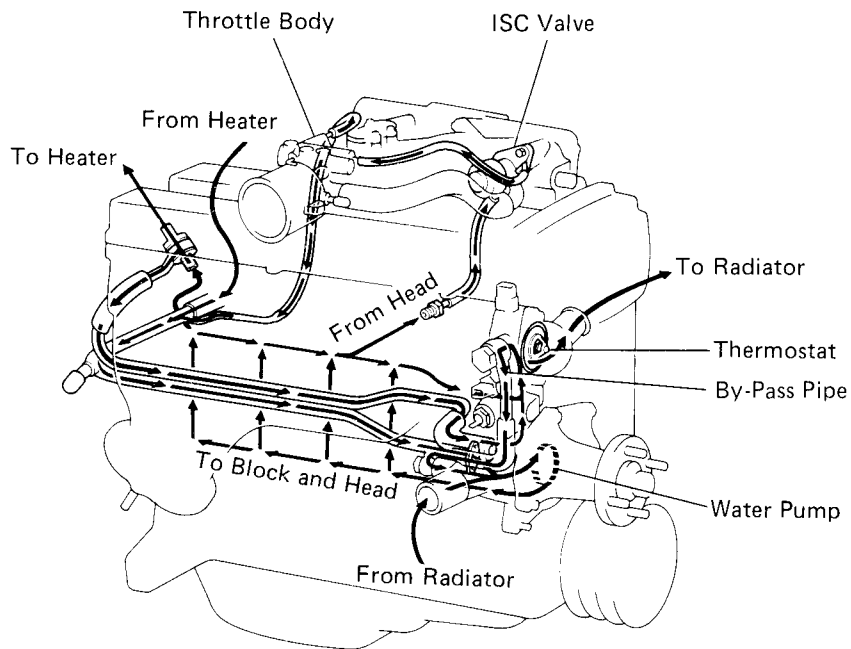

COOLING SYSTEM

	Page
DESCRIPTION	CO-2
TROUBLESHOOTING	CO-4
CHECK AND REPLACEMENT OF ENGINE COOLANT	CO-5
WATER PUMP	CO-6
THERMOSTAT	CO-8
RADIATOR	CO-9

DESCRIPTION

This engine utilizes a pressurized water forced circulation cooling system which includes a thermostat equipped mounted on the outlet side.

7M-GE



7M-GTE

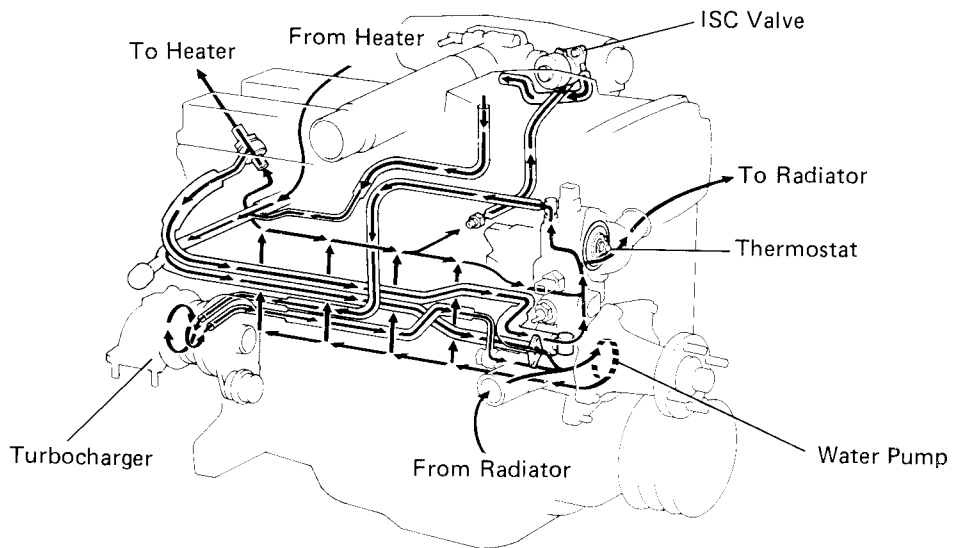

The cooling system is composed of the water jacket (inside the cylinder block and cylinder head), radiator, water pump, thermostat, cooling fan, hoses and other components.

Coolant which is heated in the water jacket is pumped to the radiator, through which an cooling fan blows air to cool the coolant as it passes through. Coolant which has been cooled is then sent back to the engine by the water pump, where it cools the engine.

The water jacket is a network of channels in the shell of the cylinder block and cylinder head through which coolant passes. It is designed to provide adequate cooling of the cylinders and combustion chambers which become the hottest during engine operation.

RADIATOR

The radiator performs the function of cooling the coolant which has passed through the water jacket and become hot, and is mounted in the front of the vehicle. The radiator consists of an upper tank and lower tank, and a core which connects the two tanks. The upper tank contains the inlet for coolant from the water jacket and the filter inlet. It also has a hose attached through which excess coolant or steam can flow. The lower tank contains the outlet for coolant and the drain cock. The core contains many tubes through which coolant flows from the upper tank to the lower tank as well as cooling fins which radiate heat away from the coolant in the tubes. The air sucked through the radiator by cooling fan, as well as the wind generated by the vehicle's travel, passes through the radiator, cooling it. Models with automatic transmissions include an automatic transmission fluid cooler built into the lower tank of the radiator.

RADIATOR CAP

The radiator cap is a pressure type cap which seals the radiator, resulting in pressurization of the radiator as the coolant expands. The pressurization prevents the coolant from boiling even when the coolant temperature exceeds 100°C (212°F). A relief valve (pressurization valve) and a vacuum valve (negative pressure valve) are built into the radiator cap. The relief valve opens and lets steam escape through the overflow pipe when the pressure generated inside the cooling system exceeds the limit (coolant temperature: 110 — 120°C, (230 — 248°F), pressure; 0.65 — 1.05 kg/cm², (9.2 — 14.9 psi, 63.7 — 103.0 kPa). The vacuum valve opens to alleviate the vacuum which develops in the coolant system after the engine is stopped and the coolant temperature drops. The valve's opening allows the pressure in the cooling system to return to the coolant in the reservoir tank.

RESERVOIR TANK

The reservoir tank is used to catch coolant which overflows the cooling system as a result of volumetric expansion when the coolant is heated. The coolant in the reservoir tank returns to the radiator when the coolant temperature drops, thus keeping the radiator full at all times and avoiding needless coolant loss. Check the reservoir tank level to see if the coolant needs to be replenished.

WATER PUMP

The water pump is used for forced circulation of coolant through the cooling system. It is mounted on the front of the cylinder block and driven by a V-ribbed belt.

THERMOSTAT

The thermostat is a wax type one and is mounted in the water outlet housing. The thermostat includes a type of automatic valve operated by fluctuations in the coolant temperature. This valve closes when the coolant temperature drops, preventing the circulation of coolant through the engine and thus permitting the engine to warm up rapidly. The valve opens when the coolant temperature has risen, allowing the circulation of coolant. Wax inside the thermostat expands when heated and contracts when cooled. Heating the wax thus generates pressure which overpowers the force of the spring which keeps the valve closed, thus opening the valve. When the wax cools, its contraction causes the force of the spring to take effect once more, closing the valve. The thermostat in this engine operates at a temperature of 88°C (190°F).

TROUBLESHOOTING

Problem	Possible cause	Remedy	Page
Engine overheats	Alternator drive belt loose or missing	Adjust or replace belt	CH-3
	Dirt, leaves or insects in radiator or condenser	Clean radiator or condenser	
	Hoses, water pump, water outlet housing, radiator, heater, core plugs or head gasket leakage	Repair as necessary	
	Thermostat faulty	Check thermostat	CO-8
	Ignition timing retarded	Set timing	IG-20
	Fluid coupling faulty	Replace fluid coupling	CO-6
	Radiator hose plugged or rotted	Replace hose	
	Water pump faulty	Replace water pump	CO-6
	Radiator plugged or cap faulty	Check radiator	CO-9
	Cylinder head or block cracked or plugged	Repair as necessary	

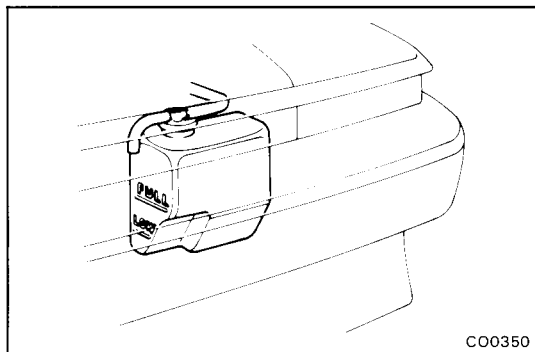

CHECK AND REPLACEMENT OF ENGINE COOLANT

1. CHECK ENGINE COOLANT LEVEL AT RESERVE TANK

The coolant level should be between the "LOW" and "FULL" lines at low temperature.

If low, check for leaks and add coolant up to the "FULL" line.

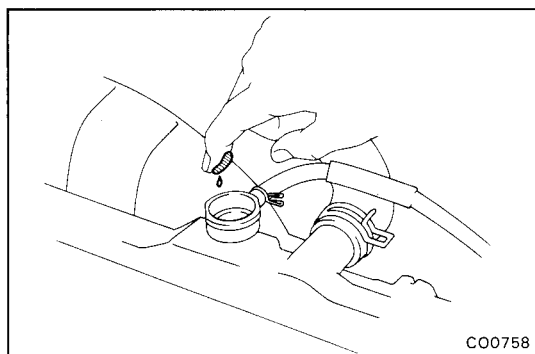

2. CHECK ENGINE COOLANT QUALITY

There should not be any excessive deposits of rust or scales around the radiator cap or radiator filler hole, and the coolant should be free from oil.

If excessively dirty, replace the coolant.

3. REPLACE ENGINE COOLANT

(a) Remove the radiator cap.

CAUTION: To avoid the danger of being burned, do not remove it while the engine and radiator are still hot, as fluid and steam can be blown out under pressure.

(b) Drain the coolant from radiator and engine drain cocks. (Engine drain is at right rear of cylinder block.)

(c) Apply sealant to the threads of the engine drain cock.

Sealant: Part No. 08833-00070, THREE BOND 1324 or equivalent

(d) Close the drain cocks.

Torque (Engine drain cock):
350 kg-cm (25 ft-lb, 34 N·m)

(e) Fill system with coolant.

Use a good brand of ethylene-glycol base coolant, mixed according to the manufacturer's directions.

Using coolant which includes more than 50% ethylene-glycol (but not more than 70%) is recommended.

NOTICE:

- Do not use alcohol type coolant.
- The coolant should be mixed with demineralized water or distilled water.

Capacity:

7M-GE

M/T 8.1 liters (8.5 US qts, 7.1 Imp. qts)

A/T 8.0 liters (8.5 US qts, 7.0 Imp. qts)

7M-GTE

M/T 8.2 liters (8.7 US qts, 7.2 Imp. qts)

A/T 8.1 liters (8.5 US qts, 7.1 Imp. qts)

(f) Install the radiator cap.

(g) Start the engine and check for leaks.

(h) Recheck the coolant level and refill as necessary.

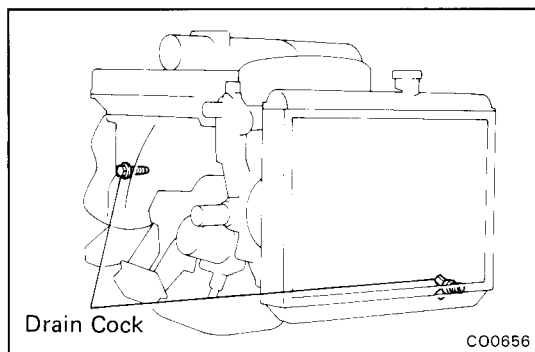

WATER PUMP COMPONENTS

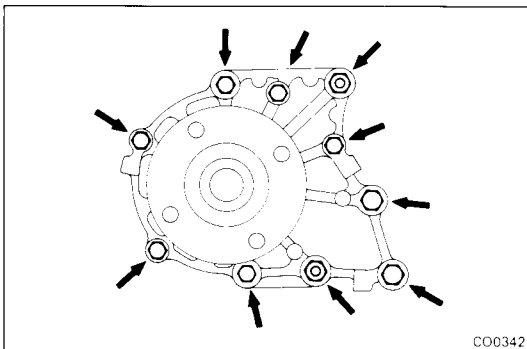
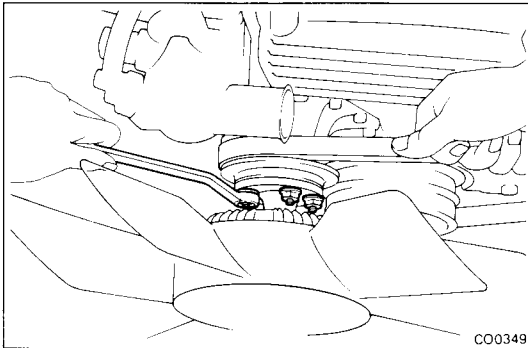
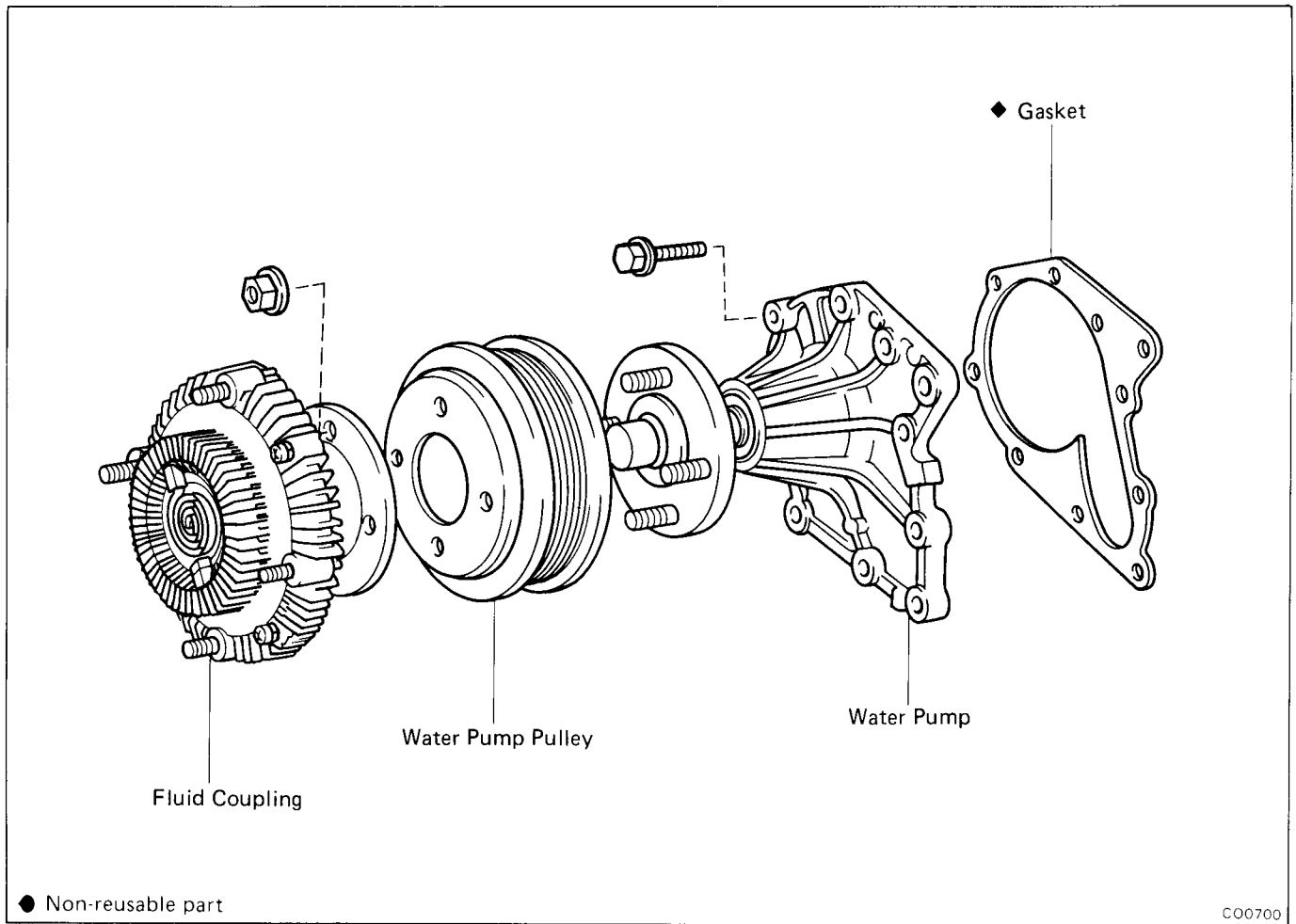

REMOVAL OF WATER PUMP

1. **DRAIN COOLANT**
2. **REMOVE A/C BELT**
3. **REMOVE ALTERNATOR DRIVE BELT, FLUID COUPLING AND WATER PUMP PULLEY**
 - (a) Loosen the water pump pulley set nuts.
 - (b) Loosen the pivot bolt, adjusting bolt and nut, and remove the drive belt.
 - (c) Remove the four nuts, fluid coupling and water pump pulley.
 - (d) Remove the fan from the fluid coupling.
4. **REMOVE PS AIR PIPE**
5. **REMOVE WATER PUMP**
Remove the eight bolts and two nuts, and remove the water pump and gasket.

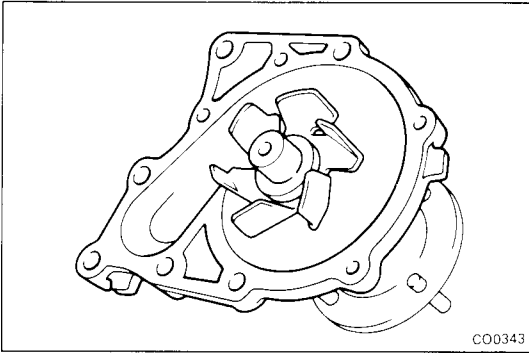

INSPECTION OF WATER PUMP

1. INSPECT WATER PUMP BODY AND TIMING BELT CASE

Check the water pump body and timing belt case for cracks and damaged gasket surfaces.

If necessary, replace the water pump or timing belt case.

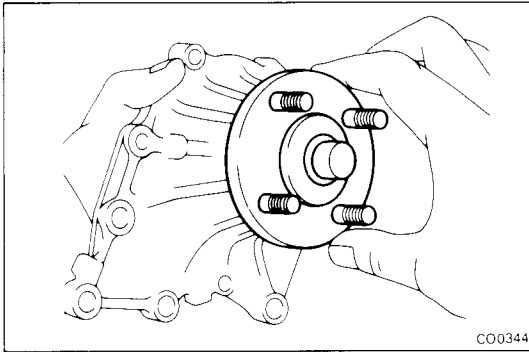

2. INSPECT WATER PUMP BEARING

Turn the pulley and check that the water pump bearing moves smoothly and quietly.

If necessary, replace the water pump.

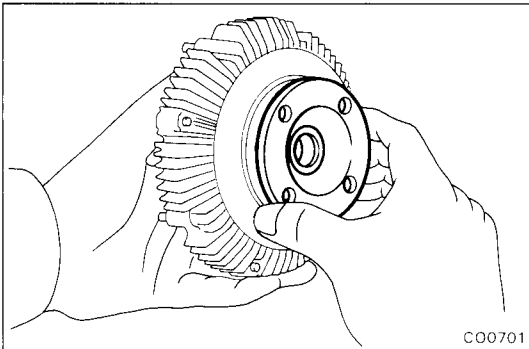

3. INSPECT FLUID COUPLING

Check that the fluid coupling is not damaged and that no silicon oil leaks.

If necessary, replace the fluid coupling.

INSTALLATION OF WATER PUMP

(See page CO-6)

1. INSTALL WATER PUMP

Install the water pump on a new gasket with the eight bolts and two nuts.

Torque:

10 mm bolt

90 kg-cm (78 in.-lb, 8.8 N·m)

12 mm head bolt and nut

195 kg-cm (14 ft-lb, 20 N·m)

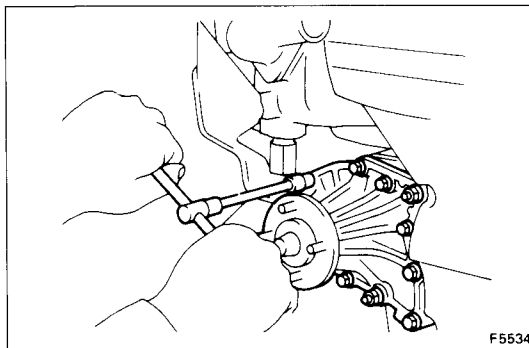

2. INSTALL PS AIR PIPE

3. INSTALL WATER PUMP PULLEY, FLUID COUPLING AND ALTERNATOR DRIVE BELT

(a) Install the water pump pulley and fluid coupling with the four nuts.

(b) Place the fan belt on to each pulley.

(c) Stretch the belt tight and tighten the four nuts.

4. INSTALL A/C BELT

5. ADJUST ALTERNATOR DRIVE BELT TENSION (See page MA-4)

6. FILL WITH COOLANT

7. START ENGINE AND CHECK FOR LEAKS

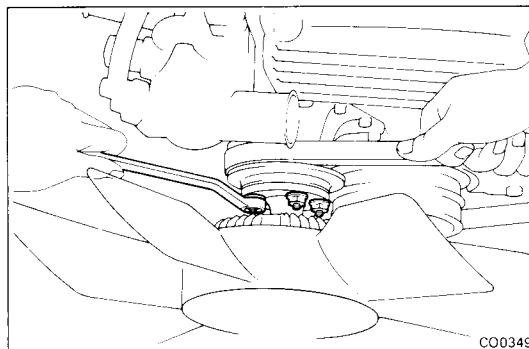

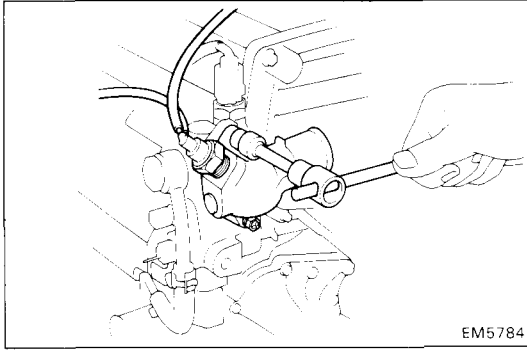

THERMOSTAT

REMOVAL OF THERMOSTAT

1. DRAIN COOLANT
2. REMOVE WATER OUTLET AND THERMOSTAT
 - (a) Remove the two bolts, water outlet and thermostat with gasket from the water outlet housing.
 - (b) Remove the gasket from the thermostat.

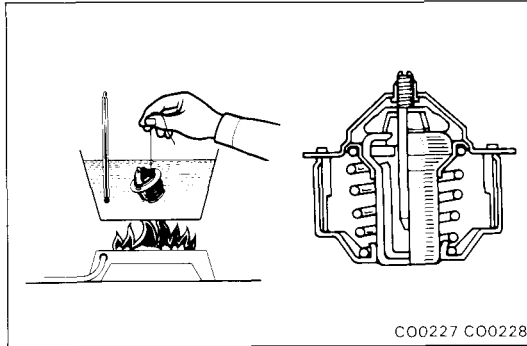

INSPECTION OF THERMOSTAT

INSPECT THERMOSTAT

HINT: Thermostat is numbered according to the valve opening temperature.

- (a) Immerse the thermostat in water and heat the water gradually.
- (b) Check the valve opening temperature.

Valve opening temperature:

86 — 90°C (187 — 194°F)

If the valve opening temperature is not within specification, replace the thermostat.

- (c) Check the valve lift.

Valve lift:

8 mm (0.31 in.) or more at 100°C (212°F)

If the valve lift is less than specification, replace the thermostat.

- (d) Check that the valve spring is tight when the thermostat is fully closed.

If necessary, replace the thermostat.

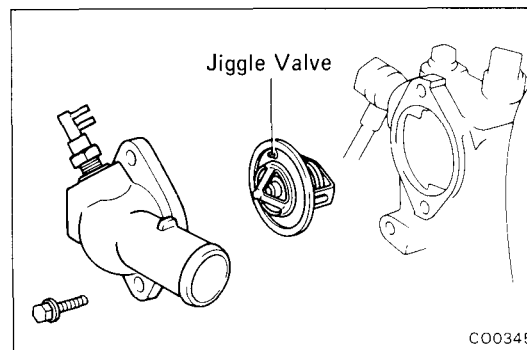
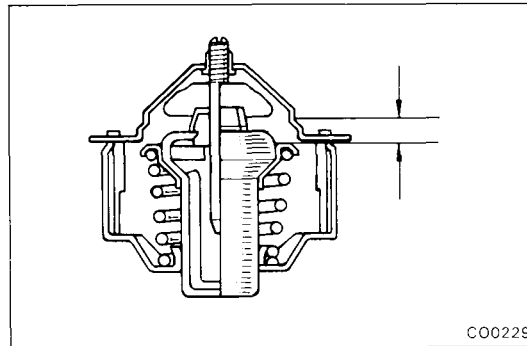

INSTALLATION OF THERMOSTAT

1. INSTALL THERMOSTAT AND WATER OUTLET
 - (a) Place a new gasket to the thermostat.
 - (b) Install the thermostat with the jiggle valve facing upward as shown in the illustration, and water outlet with the two bolts.

Torque: 80 kg-cm (69 in.-lb, 7.8 N·m)

2. FILL WITH COOLANT
3. START ENGINE AND CHECK FOR LEAKS

RADIATOR

CLEANING OF RADIATOR

Using water or a steam cleaner, remove any mud and dirt from the radiator core.

NOTICE: If using a high pressure type cleaner, be careful not to deform the fins of the radiator core. If the cleaner nozzle pressure is 30 — 35 kg/cm² (427 — 498 psi, 2,942 — 3,432), keep a distance of at least 40 — 50 cm (15.75 — 19.69 in.) between the radiator core and cleaner nozzle.

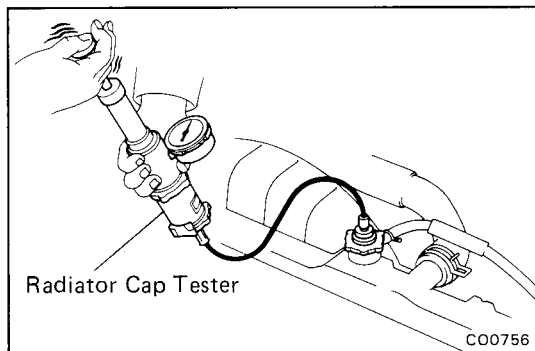
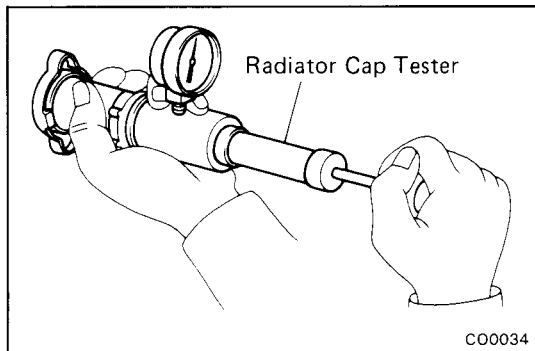

INSPECTION OF RADIATOR

1. CHECK RADIATOR CAP

Using a radiator cap tester, pump tester until the relief valve opens. Check that the valve opens between 0.75 kg/cm² (10.7 psi, 74 kPa) and 1.05 kg/cm² (14.9 psi, 103 kPa).

Check that the pressure gauge does not drop rapidly when pressure on the cap is below 0.6 kg/cm² (8.5 psi, 59 kPa).

If either check is not within limits, replace cap.

2. CHECK COOLING SYSTEM FOR LEAKS

(a) Fill the radiator with coolant and attach a pressure tester.

(b) Warm up the engine.

(c) Pump it to 1.2 kg/cm² (17.1 psi, 118 kPa), check that pressure does not drop.

If the pressure drops, check for leaks from the hoses, radiator or water pump. If no external leaks are found, check the heater core, cylinder block and head.

REMOVAL OF RADIATOR

1. DRAIN COOLANT

2. DISCONNECT CONDENSER FAN MOTOR CONNECTOR

3. DISCONNECT RADIATOR HOSES

4. DISCONNECT COOLANT RESERVOIR HOSE

5. (A/T) DISCONNECT A/T COOLER HOSES

HINT:

- Be careful as some oil will leak out. Catch it in a suitable container.
- Plug the pipe to prevent oil from escaping.

6. REMOVE RADIATOR SUPPORTS AND RADIATOR

7. REMOVE CONDENSER FAN MOTORS

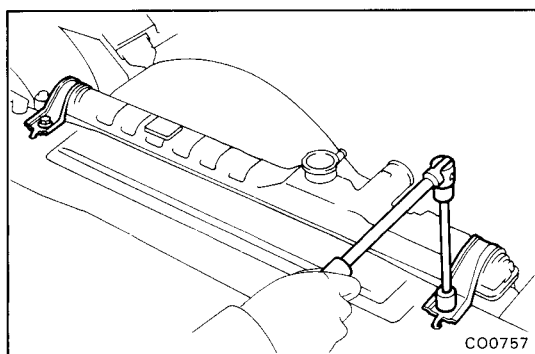

COMPONENTS

7M-GE (A/T)

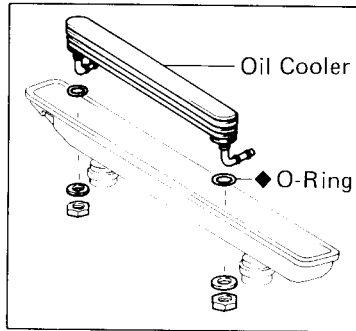

7M-GTE (A/T)

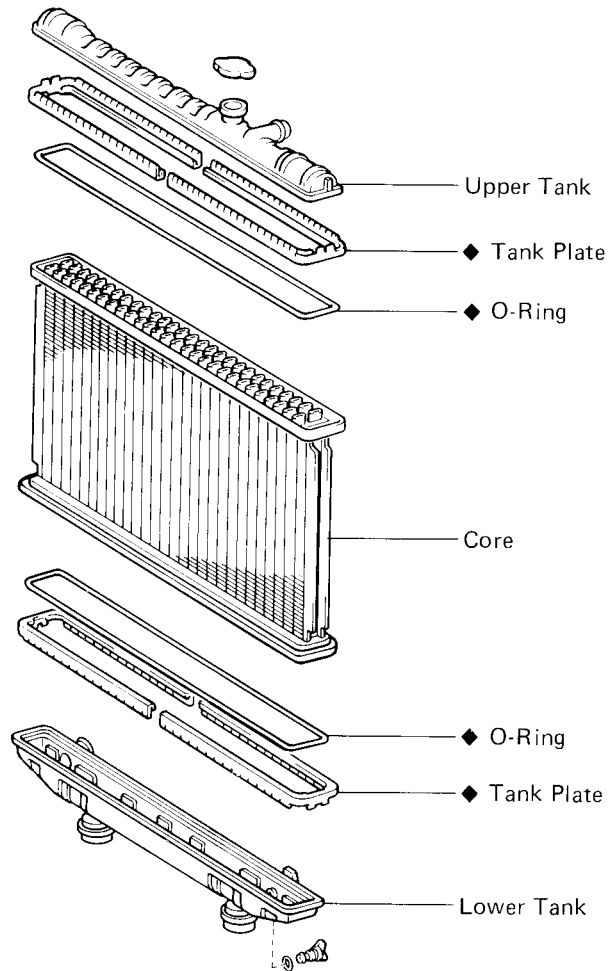
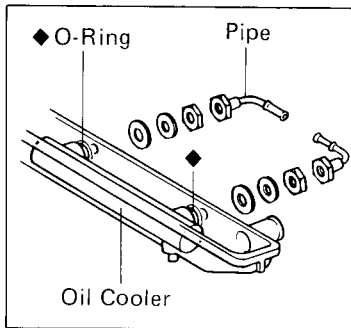

◆ Non-reusable part

CO0556

DISASSEMBLY OF RADIATOR

1. REMOVE TANK PLATE

(a) Raise the claws of the tank plates with SST in the numerical order shown in the figure.

SST 09230-00010

HINT: Be careful not to damage the core plate.

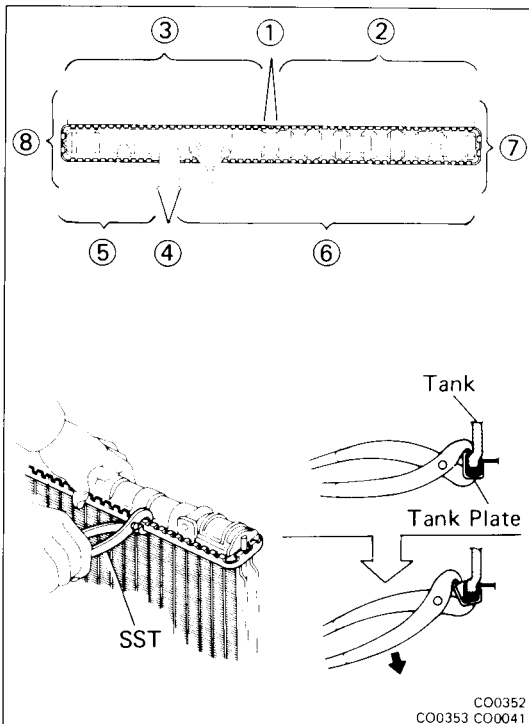

CO0352
CO0353 CO0041

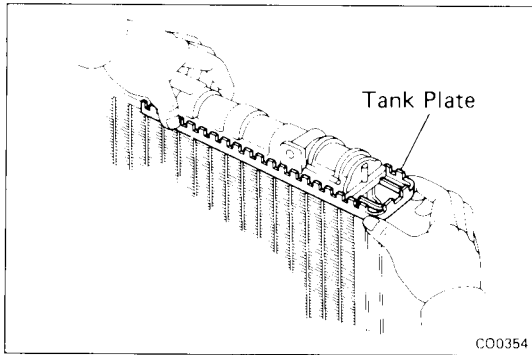

(b) Pull the tank plates outward.

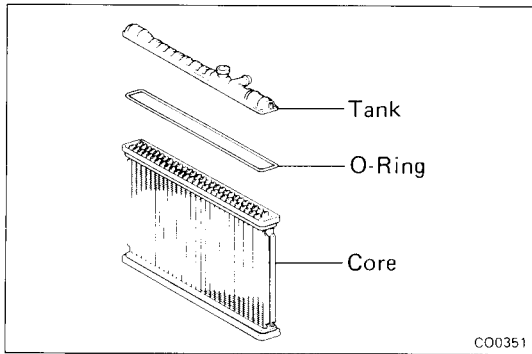

2. REMOVE TANK AND O-RING

- (a) Pull the tank upward.
- (b) Remove the O-ring.

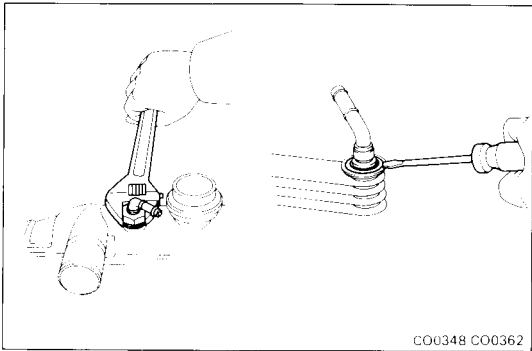

**3. (A/T)
REMOVE OIL COOLER FROM LOWER TANK**

- (a) 7M-GE
Remove the pipes.

HINT: Make a note of the direction the pipes face.

- (b) Remove the nuts, spring washers, plate washers and oil cooler.
- (c) Remove the O-rings from the oil cooler.

ASSEMBLY OF RADIATOR

(See page CO-10)

**1. INSTALL OIL COOLER TO LOWER TANK
[7M-GE (A/T)]**

- (a) Clean the O-ring contact surface of the lower tank and oil cooler.
- (b) Install new O-rings (1) to the oil cooler (2).
- (c) Install the oil cooler (2) with O-rings (1) to the lower tank (3).
- (d) Install the plate washers (4), spring washers (5), and nuts (6). Torque the nuts (6).

Torque: 220 kg-cm (16 ft-lb, 22 N·m)

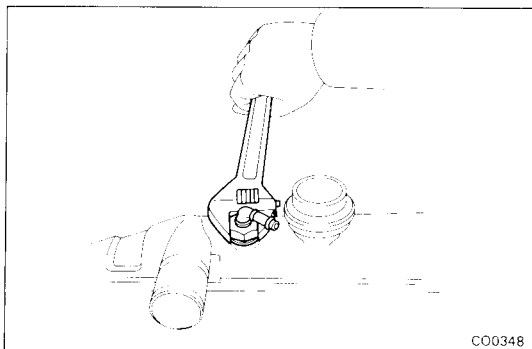
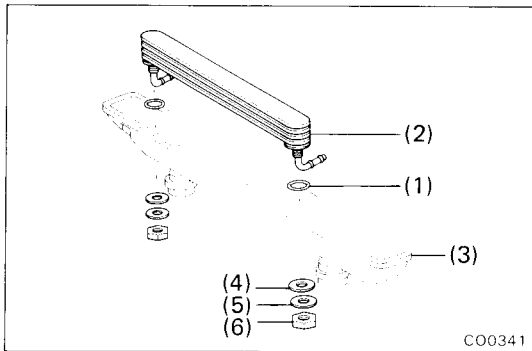

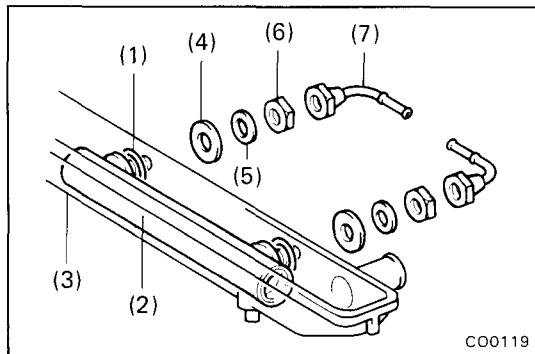

[7M-GTE (A/T)]

- (a) Clean the O-ring contact surface of the lower tank and oil cooler.
- (b) Install new O-rings (1) to the oil cooler (2).
- (c) Install the oil cooler (2) with the O-rings (1) to the lower tank (3).
- (d) Install the plate washers (4), spring washers (5) and nuts (6). Torque the nuts (6).

Torque: 220 kg-cm (16 ft-lb, 22 N·m)

- (e) Install the pipes (7).

Torque: 150 kg-cm (11 ft-lb, 15 N·m)

HINT: Face the pipes in the same direction they were before disassembly.

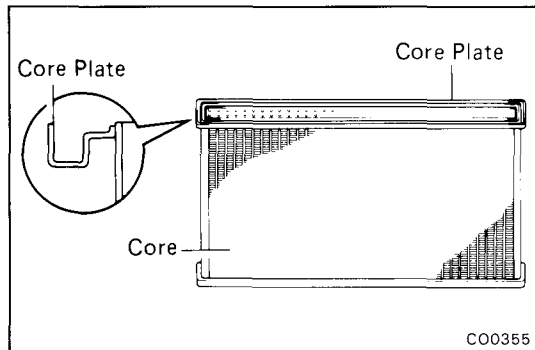
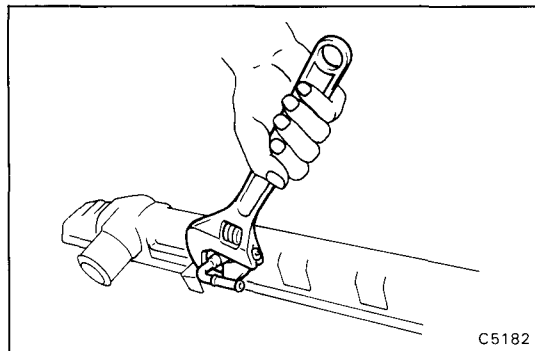

2. INSPECT CORE PLATE

Inspect the core plate for damage.

HINT:

- If the sides of the core plate groove are deformed, reassembly of the tank will be impossible. Therefore, first correct any deformation with pliers.
- Water leakage will result if the bottom of the core plate groove is damaged or dented. Therefore, repair or replace if damaged.

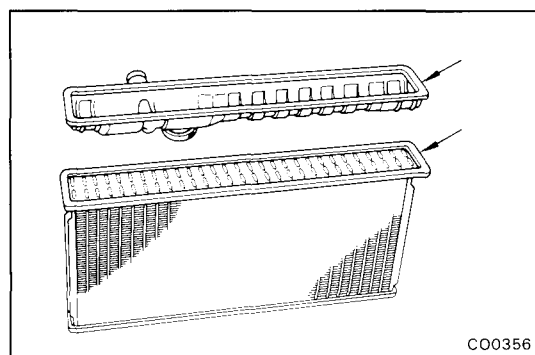

3. INSTALL NEW O-RING AND TANK

HINT:

- Clean the tank and core plate.

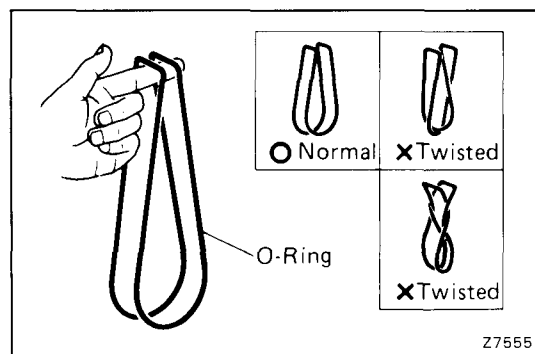

- Take out any twists.

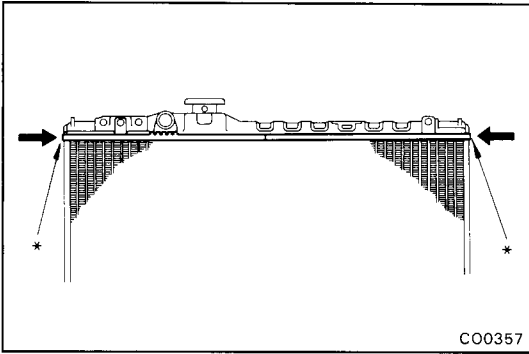

4. INSTALL TANK PLATE

Insert the tank plates from both ends in the direction of the arrows. Insert to where the portions marked " * " make contact with the tank.

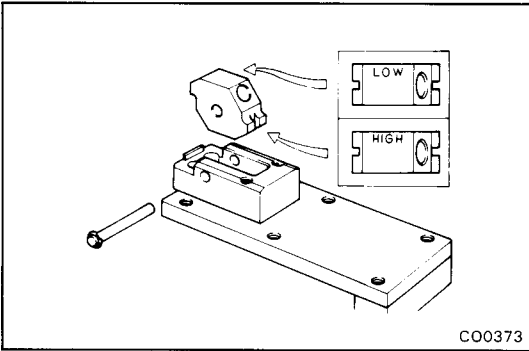

5. STAKE CLAW OF TANK PLATE

(a) Set the punch on SST to "LOW."
SST 09230-00010

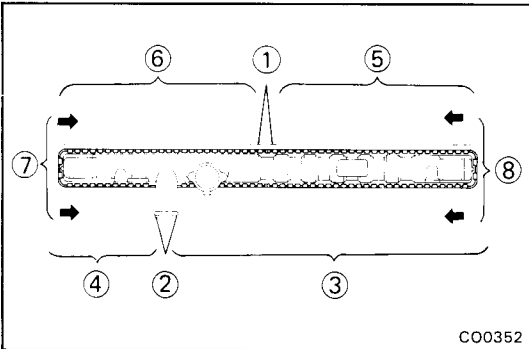

(b) Stake the claws of the tank plates with SST in the numerical order shown in the illustration.

SST 09230-00010

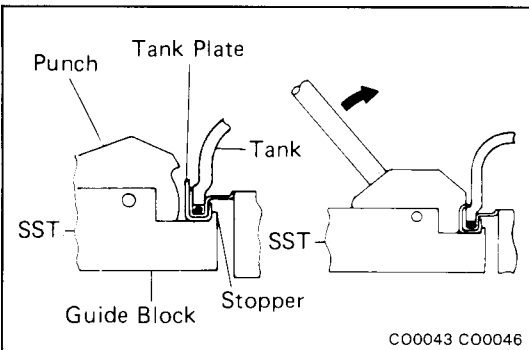

NOTICE: If the bottom of the core plate is staked with the SST on the guide block stopper, it may result in water leakage.

SST 09230-00010

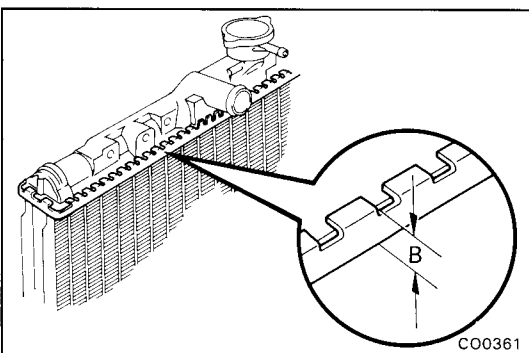

HINT:

- Stake with just enough pressure to leave a mark on the claw. The staked plate height "B" should be as follows:

Plate height: 9.18 — 9.53 mm (0.3614 — 0.3752 in.)

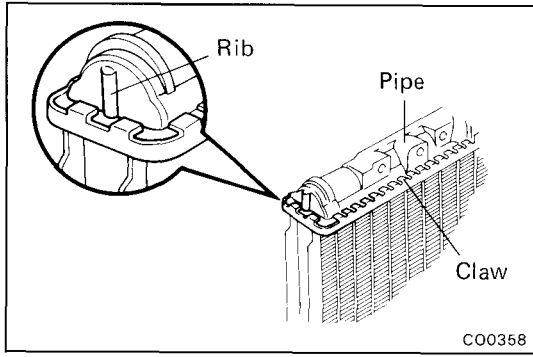

- Do not stake the areas protruding around the pipes, brackets or tank ribs.

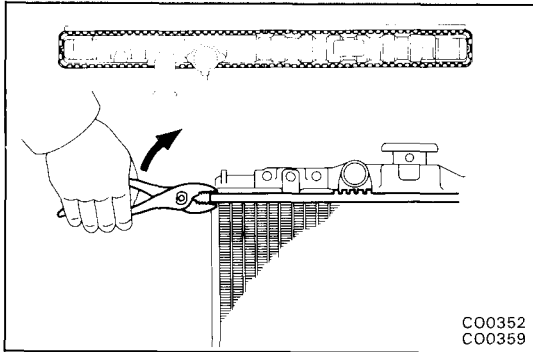

- The points shown in the illustration cannot be staked with the SST. Use pliers and be careful not to damage the core plate.

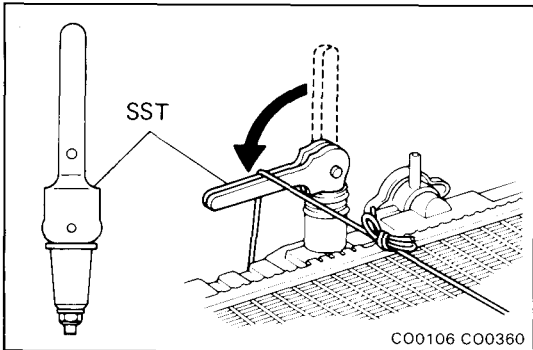

6. INSPECT FOR WATER LEAKS

- Tighten the drain plug.
- Plug the oil cooler pipes to prevent any water leakage into the oil cooler.
- Plug the inlet and outlet pipes of the radiator with SST.

SST 09230-00010

- Using a radiator tester, apply pressure to the radiator.

Test pressure: 1.5 kg/cm² (21 psi, 147 kPa)

- Inspect for water leaks.

HINT: On radiators with resin tanks, there is a clearance between the core plate and tank plate where a minute amount of air will remain, giving the appearance of an air leak when the radiator is submerged in water. Therefore, before performing the water leak test, first swish the radiator around in the water until all air bubbles disappear.

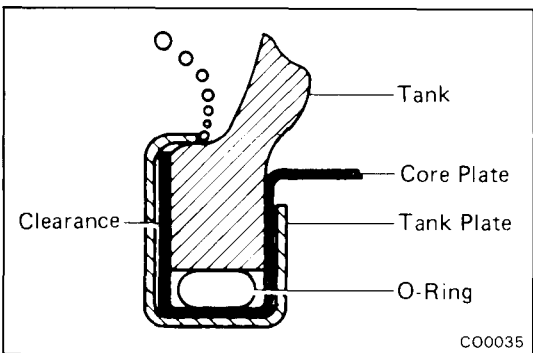

7. PAINT TANK PLATES

HINT: If the water leak test checks out okay, allow the radiator to completely dry and then paint the tank plates.

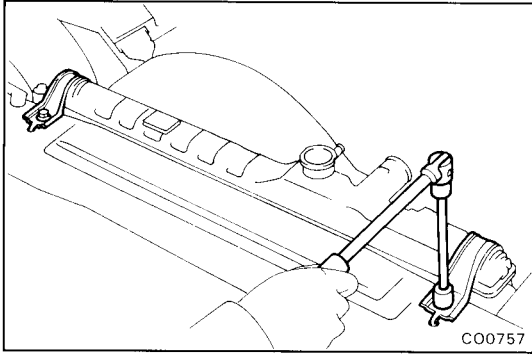

INSTALLATION OF RADIATOR

1. **INSTALL CONDENSER FAN MOTORS**
2. **INSTALL RADIATOR**
Place the radiator in installed position and install the supports with the bolts.
3. **(A/T)**
CONNECT A/T COOLER HOSES
4. **CONNECT COOLANT RESERVOIR HOSE**
5. **CONNECT RADIATOR HOSES**
6. **CONNECT CONDENSER FAN MOTOR CONNECTORS**
7. **FILL WITH COOLANT**
(See page CO-5)
8. **START ENGINE AND CHECK FOR LEAKS**
9. **(A/T)**
CHECK AUTOMATIC TRANSMISSION FLUID LEVEL
(See page AT-18)

